

ECOdrive 12W Nano Family LED Drivers Developed for Europe, Australia & New Zealand



The eldoLED ECOdrive 12W Nano LED driver family has been designed for downlighting and tubular or pendant lighting applications in Europe, Australia and New Zealand. The plastic housing is designed to fit through small cut-outs or inside cylindrical fixtures (down to 35mm). The product range includes:

- an independent (stand-alone) version with strain relief
- a connectorized version (with Wieland GST15i2 connectors)
- a built-in version.

The driver has a wire pigtail (output wire to LEDs).

This dimmable ECOdrive family has DALI-2 (DT6), Pulse dimming and Phase dimming down to 1% (dimmer dependent for Phase dimming products).

The DALI products can be programmed with eldoLED® studio (wired or wireless). DALI drivers with LEDcode can be connected to a Casambi wireless control module by eldoLED and can be configured to LEDcode Cross mode.

The Phase dimming products can be configured via a dipswitch.

For DALI models an Environmental Product Declaration (EPD) is available on the product webpage.

Applications

- Downlight
- Commercial (hospitality, office, healthcare)
- Residential
- Architectural

Products

Product	Max Power	Dimming	Nominal Output Current	Output Voltage Range	Control Protocol	Housing	Order Number**
ECOdrive	13W	Dim to 1%	150-700mA*	5-43V	DALI-2, Pulse dimming	NA	EC12NA-E1Z0D-NZ
ECOdrive	13W	Dim to 1%	150-700mA*	5-43V	DALI-2, Pulse dimming, LEDcode2	NA	EC12NA-E1Z0D-NL
ECOdrive	13W	Dim to 1%	150-700mA*	5-43V	DALI-2, Pulse dimming	NA	EC12NA-E1ZAD-NZ
ECOdrive	13W	Dim to 1%	150-700mA*	5-43V	DALI-2, Pulse dimming, LEDcode2	NA	EC12NA-E1ZAD-NL
ECOdrive	13W	Dim to 1%	150-700mA*	5-43V	DALI-2, Pulse dimming	N	EC12N-E1Z0D-NZ
ECOdrive	13W	Dim to 1%	150-700mA*	5-43V	DALI-2, Pulse dimming, LEDcode2	N	EC12N-E1Z0D-NL
ECOdrive	13W	Dim to 1%	150-700mA*	5-43V	DALI-2, Pulse dimming	NA	EC12NA-E1ZWD-NZ
ECOdrive	13W	Dim to 1%	150-700mA*	5-43V	DALI-2, Pulse dimming, LEDcode2	NA	EC12NA-E1ZWD-NL
ECOdrive	14W	Dim to 1%	200-250-300-350mA	20-39V	Phase dimming	NA	EC12NA-E1ZHP
ECOdrive	14W	Dim to 1%	350-500-550-700mA	11-20V	Phase dimming	NA	EC12NA-E1ZLP
ECOdrive	14W	Dim to 1%	200-250-300-350mA	20-39V	Phase dimming	N	EC12N-E1ZHP
ECOdrive	14W	Dim to 1%	350-500-550-700mA	11-20V	Phase dimming	N	EC12N-E1ZLP

1% dimming can be achieved with current setting of 150-700mA; minimum dim level for Phase dimming depends on dimmer (see chapter Dimmers).

* Minimum current level is 1.5mA. ** For explanation see the Ordering Guide

Key Features and Benefits

- Unique small size driver enabling hidden lighting with miniaturized downlights, pendants, spotlights and wall washers:
 - Independent driver that fits through 35mm aperture with 100mm plenum ceiling.
 - Wieland connector version for fast installation, also capable of fitting through 35mm aperture.
 - Built-in versions with multiple mounting options, including fitting in a 35mm tube.
- Control: supported control protocols include DALI-2, Pulse dimming, LEDcode2 devices (Casambi) and Phase dimming.
- Natural and flicker-safe dimming: Dim with smooth brightness changes, excellent flicker performance, configurable minimum dimming level* and adaptable dimming curves*.
- Regional standards: designed to meet the standards in Europe (ENEC), Australia and New Zealand (RCM)*.
- Programmable: DALI products can be fine-tuned across a wide operating window using eldoLED® studio – wireless via NFC or wired via a programming cable. Programmable features vary per model and include:
 - Dimming curve and dimming level
 - Output current (1mA resolution)
 - LEDcode Cross (transmit LEDcode input as DALI broadcast output)
- Performance: smallest driver with wide operating window, including COB operating point (36V / 350mA and 18V / 700mA). Constant current SELV output to LEDs. Drivers are pre-wired to the LEDs.
- European mains input (220-240VAC), low inrush current and Total Harmonic Distortion. Can be used up to 50°C (DALI models) and 45°C (Phase dimming models) ambient temperature. DALI models support central battery (DC) emergency.

* applies to DALI models

Specifications and Certifications



ECODrive 12W Nano Family LED Drivers – Datasheet

Ordering Guide

EC	12	N	E	1	Zx	X	Nx
Family	Output Wattage	Housing	Input Voltage	Output Channels	Connector Choice & Output Range	Control	Programming & LEDcode2*
EC=ECODrive	12W	N = Built-in version NA = with Strain Relief	E = 220-240VAC	1 = 1 Output	Z0 = screw connector, for thick input wires (6-9mm) ZA = screw connector, for thin input wires (4-6mm)** ZW = Wieland connector ZH = screw connector, High LED voltage (20-39V) ZL = screw connector, Low LED voltage (11-20V)	D = DALI DT6 P = Phase dim	NL = NFC + LEDcode2 NZ = NFC, no LEDcode2

For specific configuration settings (dimming curves, current settings), please contact your Sales representative.

*LEDcode2: to connect the driver to a Casambi wireless control module by eldoLED, or for LEDcode Cross applications.

** In case of connecting a Casambi radio and mains only, it is recommended to use the ZA model in view of input wire thickness.

Electrical Specifications

Max Output Power	Nominal Input Voltage	Max Input Current	Typ. Power Factor at Full Load	Typ. THD at Full Load	Max. Standby Power	Inrush, Max. on Circuit Breaker	Surge Protection	Typ. Efficiency at Full Load	Typ. Max Tc
DALI 13W	220-240VAC 220-250VDC	70mA	>0.95	<10%	<0.5W	130 on B16*	1kV differential L-N 2kV common L-N	>86%	72°C
Phase dim 14W	220-240VAC	80mA	>0.95	<10%	not applicable	>80 on B16	1kV differential L-N 2kV common L-N	>78%	85°C

* Inrush current (peak/duration) for 13W DALI: 2A/100µs

Operating Window

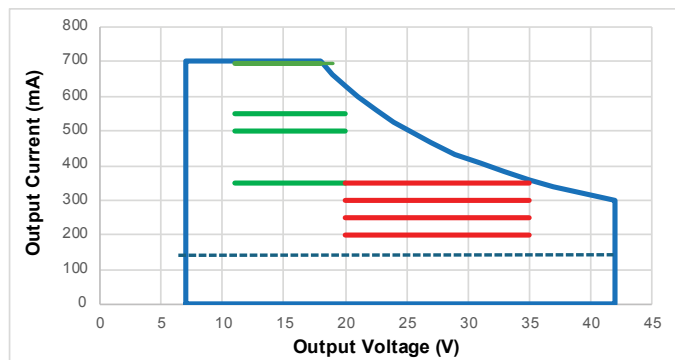

- 12W DALI
- 12W Phase dimming LV
- 12W Phase dimming HV

Tested with a load of 13 LEDs in series.

DALI drivers were programmed for 350mA at 36V and 25°C ambient temperature. The measurements were performed by dimming the light output.

Mechanical Details

	ECODrive 12W NA strain relief version with screw connectors	ECODrive 12W NA plug & play version with Wieland connectors	ECODrive 12W N, built-in version with screw connectors
Length	128.8 x 32 x 25.7mm	130.5 x 32 x 25.7mm	128.0 x 32 x 25.7mm
Weight of Individual Product	75gr	75gr	72gr
Packaging	75 pcs per box	75 pcs per box	75 pcs per box
Box Weight	6.1kg	6.1kg	5.9kg
Box Dimensions	55 x 20 x 19.5cm	55 x 20 x 19.5cm	55 x 20 x 19.5cm

ECOdrive 12W Nano Family LED Drivers – Datasheet

Strain relief version with screw connectors

EC12NA-E1Z0D-NZ/NL
 EC12NA-E1ZAD-NZ/NL
 EC12NA-E1ZHP
 EC12NA-E1ZLP

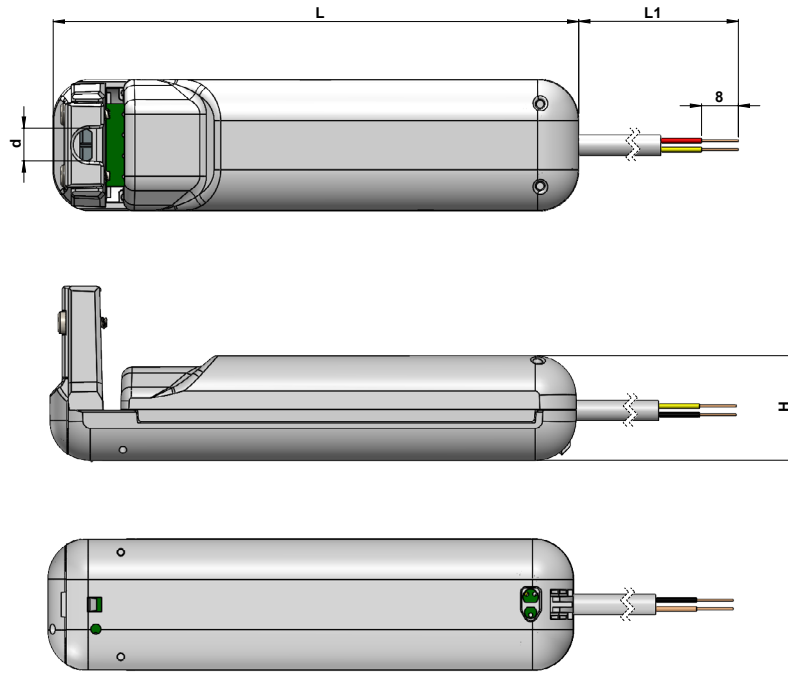
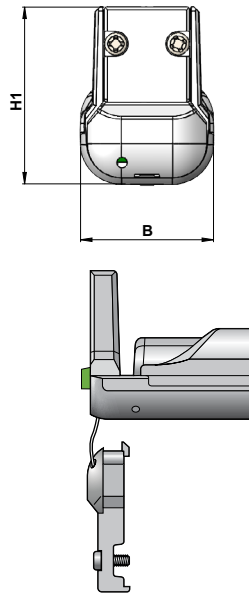

d = 8 mm
 B = 32 mm
 H1 = 42.6 mm
 H = 25.7 mm
 L1 = 178 mm (typical)*
 L = 128.8 mm

During assembly a cord is attached between cap and driver. In case the cap is reopened, e.g. during installation, it will not get lost.

Built-in version with screw connectors

EC12N-E1Z0D-NZ/NL
 EC12N-E1ZHP
 EC12N-E1ZLP

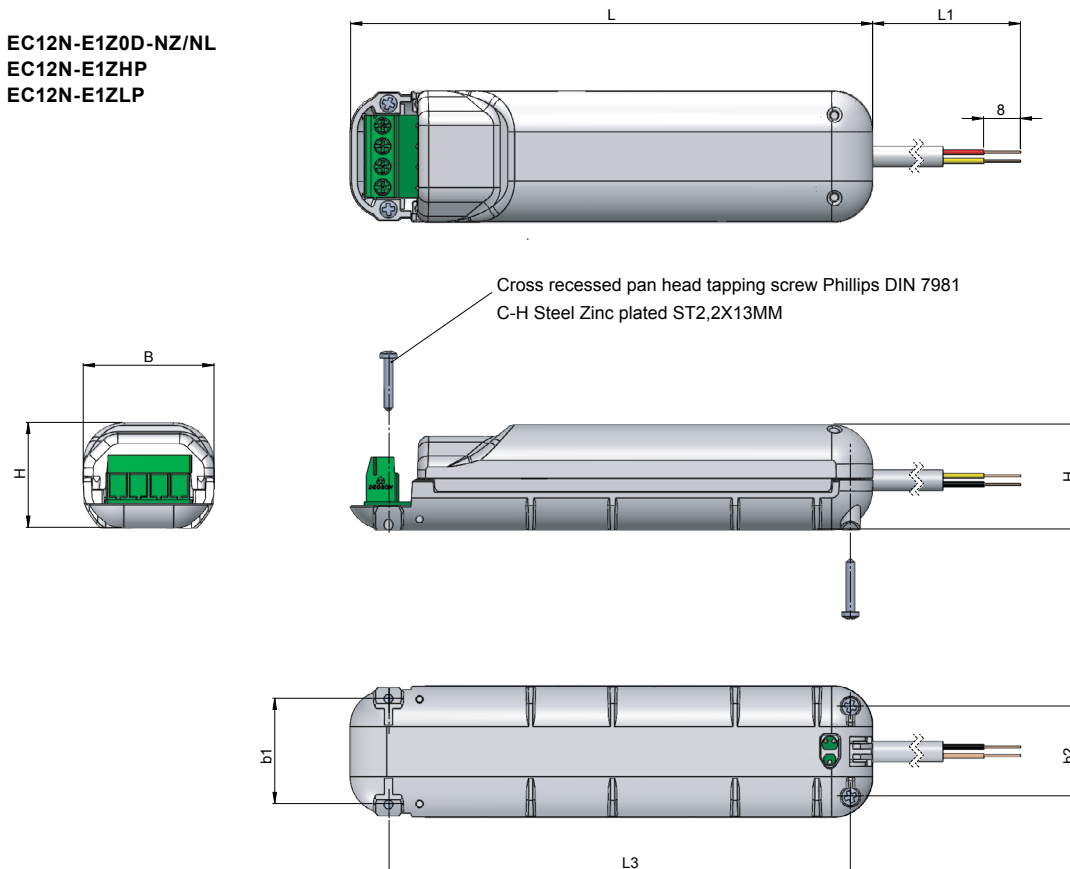

L = 127.9 mm
 L1 = 178 mm (typical)*
 B = 32 mm
 H = 25.7 mm
 b1 = 25.8 mm
 b2 = 22 mm

ECOdrive 12W Nano Family LED Drivers – Datasheet

Plug & play version with Wieland connectors

EC12NA-E1ZWD-NZ/NL

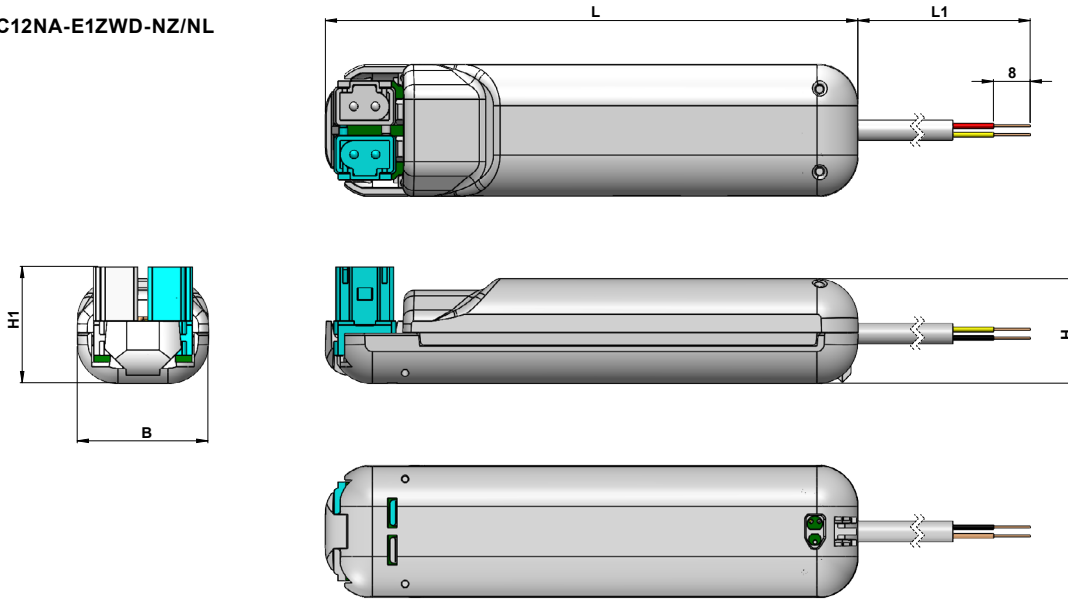

L = 130.5 mm
L1 = 178 mm (typical)*
H = 25.7 mm
H1 = 28.5 mm
B = 32 mm

* Typical length of pigtail wire is 178mm (L1). This may vary from product to product, variations upto 30mm may occur.
For different cable length or for a pre-mounted connector, please contact your Sales representative.

ECOdrive 12W Nano Family LED Drivers – Datasheet

Installation References

When installing independent drivers of the ECOdrive 12W series with nano form factor, the driver will fit through apertures of 35mm, with 100mm plenum ceilings and standard plasterboards (9-12mm thickness).

For different plasterboard thicknesses, there is a correlation between aperture diameter, ceiling thickness and minimum free space above the plenum that should be considered. Kindly refer to the diagram or table below to check the minimum values.

EC12NA-E1ZWD-NZ/NL

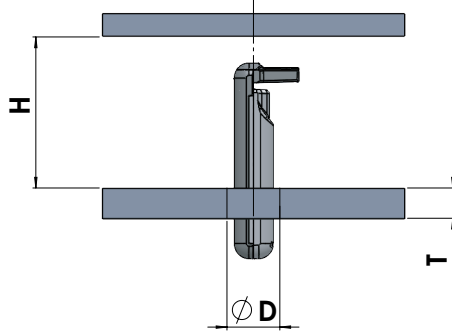

Reference table for absolute values:

	Aperture diameter (D) in mm	Min free space above plenum (H) in mm
Ceiling thickness (T): 15mm	30	(not possible)
	35	102
	40	88
	45	79
	50	69
Ceiling thickness (T): 24mm	35	(not possible)
	38	93
	40	88
	45	79
	50	69

Minimum Free Space above Plenum (H) as Function of Aperture (Cut-out) Diameter (D) for 2 different Ceiling Thicknesses (T)

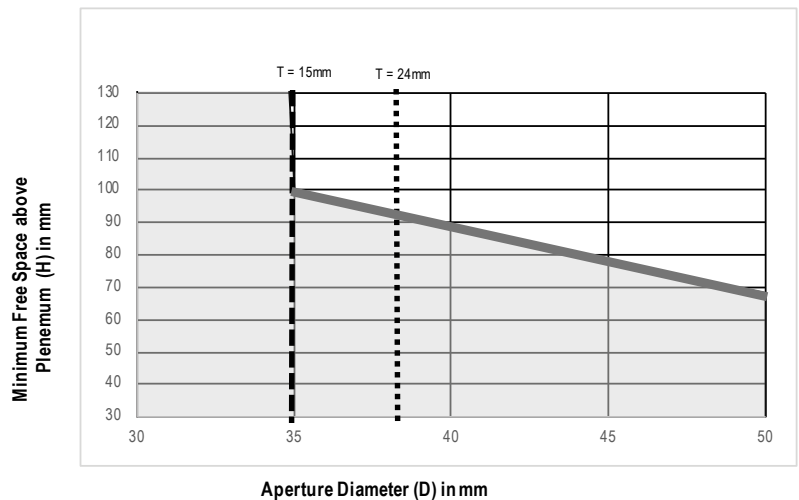

- plasterboard thickness of 15mm
- plasterboard thickness of 24mm

The white area indicates allowed combinations of aperture and free space above the plenum.

Ceiling thickness of 15mm: minimal aperture is 35mm when the free space above the plenum >100mm.
 Ceiling thickness of 24mm: minimal aperture is 38mm when the free space above the plenum >93mm.

RCM Installation Instructions

For installation in New Zealand and Australia, please adhere to the following region specific (RCM) guide lines:

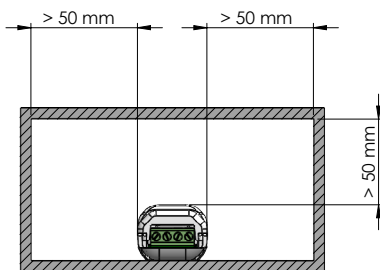

Typical Efficiency, THD and Power Factor

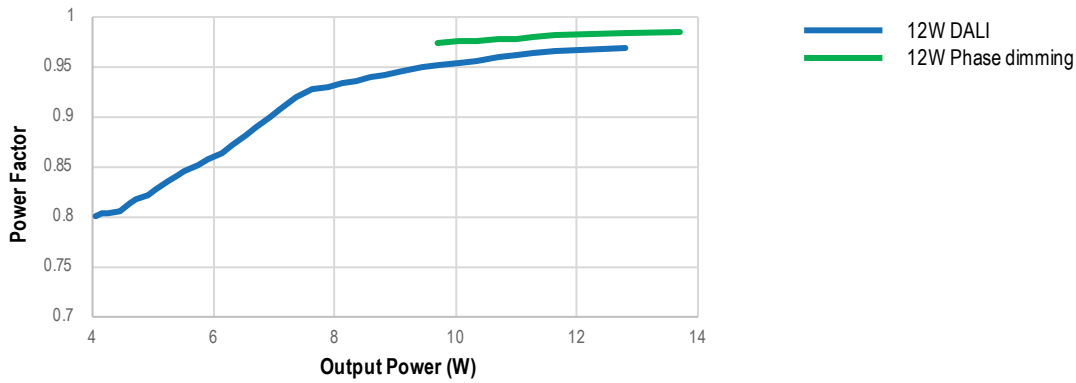
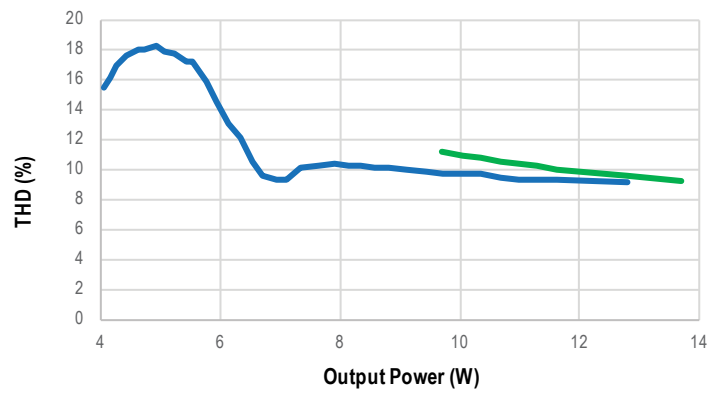
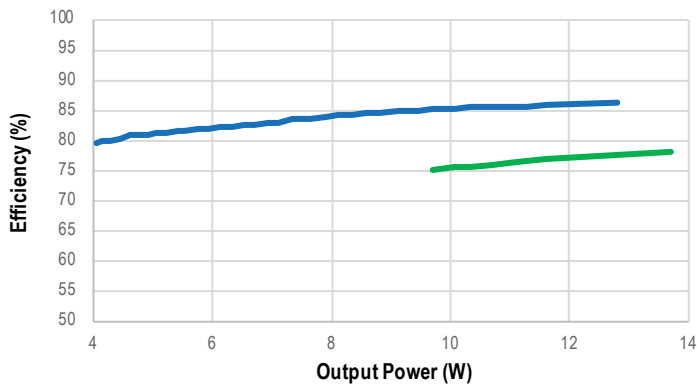

Tested with a load of 13 LEDs in series.
 DALI drivers were programmed for 350mA at 25°C ambient temperature. The measurements were performed by dimming the light output.

ECOdrive 12W Nano Family LED Drivers – Datasheet

Minimum and Maximum Ratings

Parameter	Values
Input Voltage Range (functional)	DALI products: 196-264VAC and 198-250VDC, Phase dimming products: 200-250VAC
Ambient Operating Temperature	DALI products: -20°C to 50°C, Phase dimming products: -20°C to 45°C
Lifetime	50,000 hours at maximum case temperature (Tc) Lifetime doubles per 10°C below Tc
Acoustic Noise	<24 dBA

Tc Point Location

Measuring from the back of the driver, the Tc point can be calculated as indicated in the drawing below for all ECOdrive 12W nano driver versions. The displayed driver is merely an example.

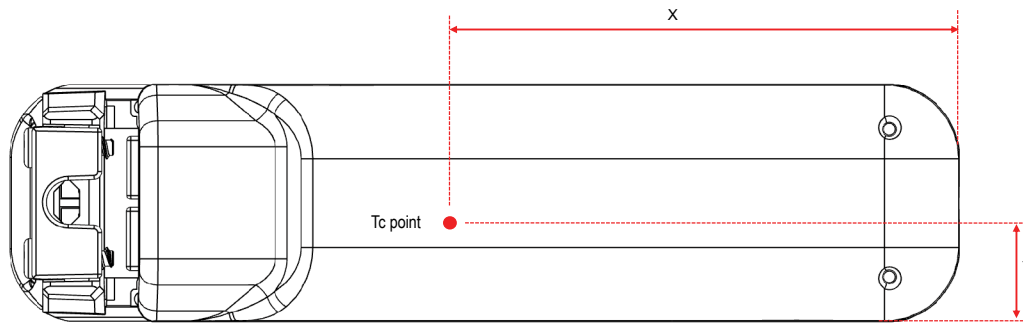

	X	Y	Tc max
ECOdrive 12W nano: DALI drivers	61.4mm	14mm	72°C
ECOdrive 12W nano: Phase dimming drivers	34.5mm	12mm	85°C

ECOdrive 12W Nano Family LED Drivers – Datasheet

Programming Tools

Programming Software	eldoLED® studio
Programming Interface	NFC (wireless) for DALI products (in line with Zhaga book 24/25) USB programming bridge (cable or cable with Jig) Dipswitch for Phase dimming products (only current setting can be configured)
Programming Bridge (Cable)	eldoLED programming bridge: PUBS-TTL3v3-HH-1
Programming Jig	Mounting clip for eldoLED programming cable: Nano Clamp-1
Programming Kit (Cable + Jig)	eldoLED programming cable with pre-mounted clip: Nano Programming Kit

Both box programming and single item programming is possible.

Standard NFC Programming Tools

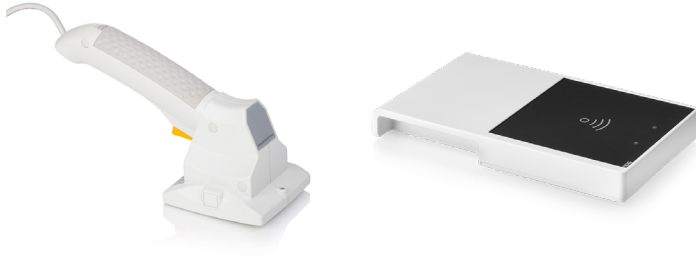

eldoLED Programming Bridge (Customized cable)



PUBS-TTL3v3-HH-1

Nano Programming Kit



Standard NFC readers from FEIG with associated type numbers (FEIG PRH101-USB, FEIG CPR30+).
Photography by FEIG Electronic.

Programming Parameters

Operating Window Settings	LED Output Current	1mA resolution – If no DALI is connected, LED output is 100% of set current (default setting is 350mA).
	Minimum Dim Level	Settable in 1mA increments down to 1.5mA (DALI products) Note: minimum dim level for Phase dimming products depends on dimmer (see chapter Dimmers)
Dimming Behavior	Dimming Curve	Selectable: LOG – Logarithmic (default) or LIN – Linear
Control Mode Setting	DALI Settings	DALI parameters
	Control Mode	Selectable: DALI (default), PulseDim, corridor mode and autodetect
	Pulse dimming Settings	PulseDim parameter settings (switch) Corridor parameter settings
	LEDcode Settings	Selectable: LEDcode Cross
	Live Control	Only via programming bridge (cable)
Emergency Lighting Mode	Light Level in DC Emergency	% vs set current (15% is default)
Driver Protection	Thermal Protection Threshold	Set temperature
	Live Temp Data	Only via programming bridge (cable)

Dimming Curves

Phase Dimming

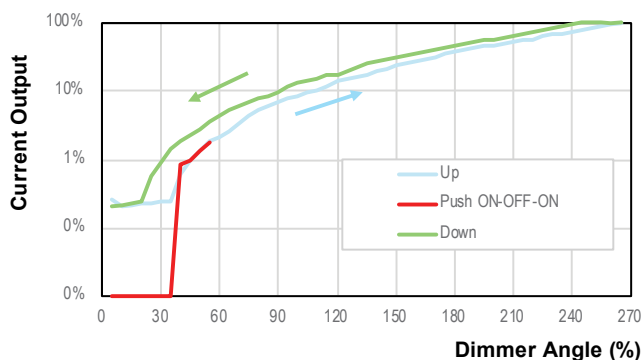

DALI

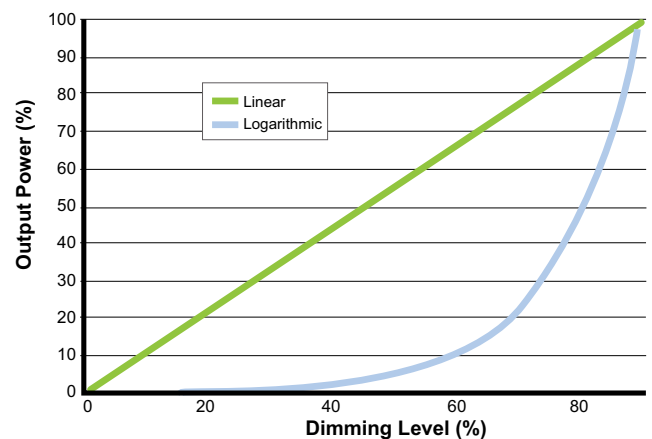

ECOdrive 12W Nano Family LED Drivers – Datasheet

Dimmers

List of tested Phase dimming dimmers:

Europe	UK
ECOdim 04	Varilight V-com MKP100
Busch Jaeger 6523 U102	Zano ZMD150
Jung GIRA 2455 00 (system 3000)	Focus SB FOC-400BV
SG LEDDIM 400	Honeywell MK K1523WHILV
ION ID200W (Mk2)	

Notes:

Test results are available on request with eldoLED Sales.

The dimming performance of Phase dimming products depends on the type of dimmer used.

Minimum dimming level or restart level can vary and depend on the amount of LED drivers connected.

Flicker Performance*

Typical performance of Phase dimming drivers

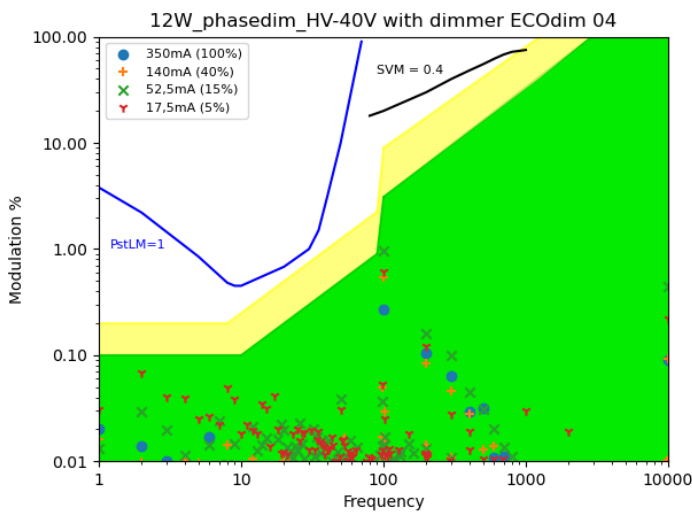

Flicker performance depends on dimmer used.

Typical performance of DALI drivers

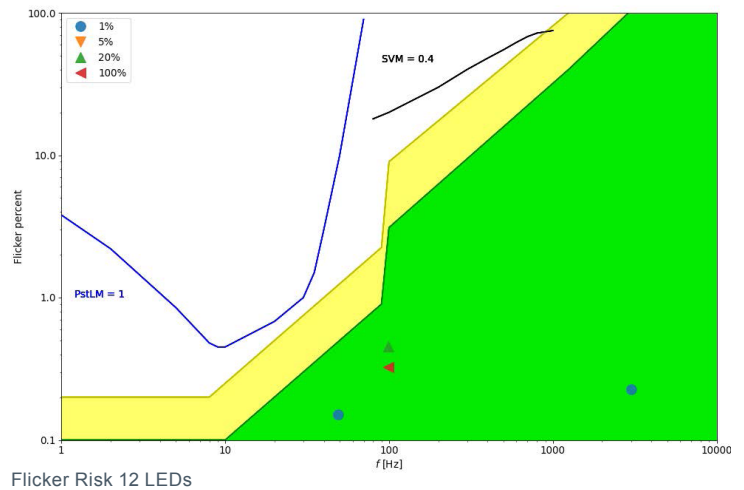

Wiring and Connector Lay Out

	Input	Output
Connector Type	Screw terminal	Wire (insulated), default 15cm wire length
Wire Type	Solid or stranded copper	Solid or stranded copper
Wire Dimensions	0.5-2.5mm ² (DALI) 0.5-1.5mm ² (Phase dimming)	0.5mm ²
Outer Jacket Thickness	6-9mm (thick) – products with ZOD in order number 4-6mm (thin) – products with ZAD, ZHP or ZLP in nomenclature	4.6mm (LED only version) 5.3mm (LED + LEDcode version)
Wire Strip Length	6mm	Standard with 5mm strip length On request with custom connector
Maximum Length To Fixture		2m for independent use

ECOdrive 12W Nano Family LED Drivers – Datasheet

Connector Lay Out (Top View)

ECOdrive DALI with LEDcode2 (Casambi)



ECOdrive DALI without LEDcode2



ECOdrive Phase dimming

	LP	HP
1=OFF 2=OFF	350mA	200mA
1=ON 2=OFF	500mA	250mA
1=OFF 2=ON	550mA	300mA
1=ON 2=ON	700mA	350mA



Wiring Diagram

DALI models with LEDcode2 (bottom view)

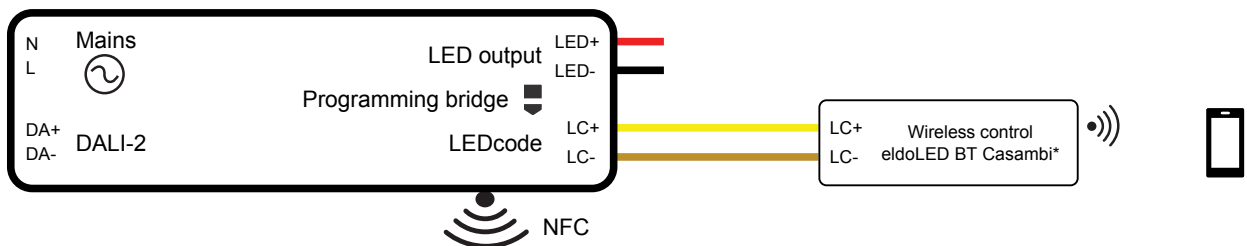

* All Casambi wireless control modules by eldoLED (see BT family datasheet)
In case of connecting a module and mains only, it is recommended to use the EC12NA-E1ZAD-NL model.

Phase dimming products (bottom view)



If applicable, connect the Phase dimmer in series on the L-line.

ECOdrive 12W Nano Family LED Drivers – Datasheet

LED Driver Protection

Thermal	The LED output current automatically decreases whenever the internal driver temperature exceeds a factory preset temperature. The LED output current increases once the internal driver temperature drops below the preset temperature threshold. If the internal driver temperature continues to increase, despite a decrease in output current, the LED driver will eventually shut down.
LED Output Short Circuit	The LED output current cuts off whenever the LED driver detects a short-circuit. The LED driver attempts a restart every 4000ms after a short circuit is detected.
LED Output Open Circuit	The LED output turns off whenever the LED driver detects an open circuit. The LED driver attempts a restart every 400ms after an open circuit is detected.
LED Output Overload	The driver monitors the LED output load. Whenever the output load exceeds the maximum output power rating of the LED driver, the output current is sequentially scaled down until the cumulative load drops below the maximum output power rating of the LED driver.
Reverse Polarity	The LED driver will not yield any current if the polarity of the load on the LED output is reversed. This situation will not damage the LED driver but may damage the LED load.

Standards and Compliance

ENEC safety	EN 61347-1 EN 61347-2-13 (Emergency lighting)*
ENEC Performance	EN 62384
RCM*	AS/NZS 61347.1, AS/NZS 61347.1.13
Conducted Emissions	EN 55015
Radiated Emissions	EN 55015
Radio Disturbance Characteristics	EN 66022
Harmonic Current Emissions	EN 61000-3-2
Electrostatic Discharge	EN 61000-4-2
RFE Field Susceptibility	EN 61000-4-3
Electrical Fast Transient	EN 61000-4-4
Surge Immunity	EN 61000-4-5
Conducted Radio Frequency	EN 61000-4-6
Voltage Dips	EN61000-4-11
Electromagnetic Immunity	EN 61547
ECOdesign 2019/2020	Flicker for LED: Pst LM ≤ 1.0 at full load Stroboscopic effect for LED: SVM ≤ 0.4 at full load
DALI-2*	IEC 62386-101 Edition 2.0, IEC 62386-102 Edition 2.0, IEC 62386-207 Edition 1
Surge Protection	IEC 61000-4-5 level3: 1kV differential L-N DM, 2kV CM @ 2 Ohm
Restriction of Hazardous Substance	RoHS3 (Directives 2011/65/EU-2015/863/EU)
SVHC-list Substances	REACH Art 33

* DALI models only

RCM Independent Control Gear Classification*

Regulation AS/NZS 60598.2.2	Applies when the control gear is built inside constructions	EN 61347-1
Clearance Type	Description	Distance
Height Clearance To Building Element (HCB)	Minimum distance between the top of the control gear and any building element above it	50 mm
Minimum Insulation Clearance (MIC)	Minimum distance between the top of the control gear and any building insulation above it	50 mm
Side Clearance To Building Element (SCB)	Minimum distance between the top of the control gear and any building element	50 mm
Side Clearance To Insulation (SCI)	Minimum distance between the top of the control gear and any building insulation	50 mm
RISK OF FIRE	BUILDING INSULATION MUST NOT COVER THE CONTROL GEAR	

* DALI models only

ECOdrive 12W Nano Family LED Drivers – Datasheet

Safety



Risk of electrical shock. May result in serious injury or death. Disconnect power before servicing or installing.



FELV control terminals marked "Risk of electric shock" are not safe to touch. Dimming connected to FELV control terminal shall be insulated for Low Voltage supply of the control gear. Any terminals connected to the FELV circuit shall be protected against accidental contact.



The LED driver may only be connected and installed by a qualified electrician. All applicable regulations, legislation, and building codes must be observed. Incorrect installation of the LED driver can cause irreparable damage to the LED driver and the connected LEDs. Pay attention when connecting the LEDs: polarity reversal results in no light output and often damages the LEDs.



LED drivers are designed and intended to operate LED loads only. Powering non-LED loads may push the LED driver outside its specified design limits and is, therefore, not covered by any warranty.



eldoLED products are designed to meet the performance specifications as outlined at certain operating conditions in the data sheet. It is the responsibility of the fixture manufacturer to test and validate the design and operation of the system under expected and potential use cases, including faults.



Please observe voltage drop over long cable lengths. Longer cable lengths increase EMI susceptibility.



Product renderings and dimensional drawings are generic for the housing type. Product label, connector type and quantity may vary.



An independent control gear that can be used where normally flammable materials, including building insulation, are or may be present, but cannot be abutted against any material and cannot be covered in normal use (applies to use in Australia and New Zealand only).

Warranty

eldoLED Products are covered by a 5-year limited warranty. This is the only warranty provided and no other statements in this datasheet create any warranty of any kind. All other express and implied warranties are disclaimed. Complete warranty terms can be found at: www.eldoled.com/legal/terms-and-conditions

Note: Actual performance may differ as a result of end-user environment and application. The product images shown are for illustration purposes only and may not be an exact representation of the product. Specifications subject to change without notice.